

SCHMEISER®

FOLDING TILL AN' PAK

ASSEMBLY & PARTS

MANUAL

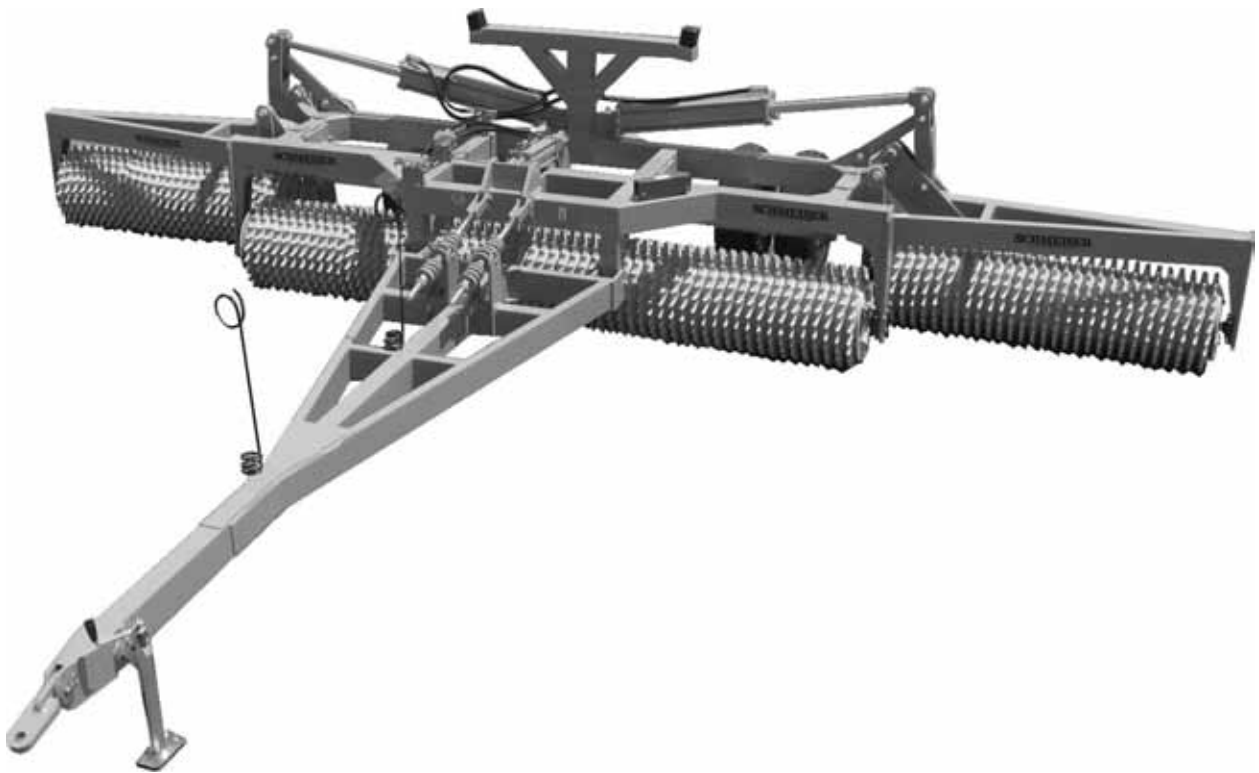

T.G. SCHMEISER CO., INC.
P.O. BOX 1047 FRESNO, CA. 93714
(559) 268-8128 FAX (559) 268-3279
www.tgschmeiser.com

VERSION 2.2
9-2009

INTRODUCTION

Your Schmeiser Folding Till An' Pak is designed to give you many years of dependable service. This manual has been prepared to instruct you in the safe and efficient operation of this machine. Read and study it thoroughly. Follow all instructions carefully.

Should your Folding Till An' Pak require replacement parts, go to your Schmeiser dealer. Always order genuine Schmeiser replacement parts.

It is important that you complete and send in your Warranty Card because it is not valid unless it is on file at Schmeiser. If you need information not contained in this manual, contact your Schmeiser dealer.

Space has been provided below for you to record the model number and serial number of your Folding Till An' Pak. Be sure to bring this information with you to your dealer when ordering parts or attachments for your Folding Till An' Pak.

Thank you for buying a Schmeiser Folding Till An' Pak.

SERIAL NUMBER _____

MODEL NUMBER _____

DATE PURCHASED _____

DEALER NAME _____

TABLE OF CONTENTS

Introduction	2
Table of Contents	3
Safety Sheet.....	4
Folding Till An' Pak Assembly.....	5
Folding Till An' Pak Square Main Frame Configurations.....	6
Folding Till An' Pak Offset Main Frame Configurations.....	7
Folding Till An' Pak Hitch Assembly	8
Folding Till An' Pak Pull Frame Assembly	9
Folding Till An' Pak Pull Frame Spring System Assembly.....	10
Folding Till An' Pak Spring System Adjustment	11
Folding Till An' Pak Hinge Linkage Assembly	12
Wheel Axle Bearing Assembly.....	13
Folding Till An' Pak Wheel Axle Assembly	14
Till An' Pak Ring Roller Assembly.....	15
Till An' Pak Tube, Ring, and Retainer Chart	16
Hydraulic Diagram for 12' Square Main Frame Units	17
Hydraulic Diagram for 12' Offset Main Frame Units.....	18
Hydraulic Diagram for 14' Square Main Frame Units.....	19
Hydraulic Diagram for 14' Offset Main Frame Units	20
Hydraulic Dia. for 14' Square Main Frame Units with 2 Hydraulic Cylinders.....	21
Hydraulic Diagram for 16' Square Main Frame Units	22
Folding Till An' Pak Sequence Valve Adjustment.....	23
Limited Warranty.....	24

SAFETY

The safe operation of any machinery is an important concern to farmers and manufactures. There are obvious and hidden potential hazards involved in the operation of this implement. Carefully read and follow all safety precautions before operation. Serious injury or death may occur unless care is taken to insure the safety of both the operator and any other persons in the area.

1. Never permit anyone to ride on or walk beside the implement when moving.
2. Never permit anyone to ride on tractor when implement is being moved.
3. When performing operating functions, never allow anyone to be near the implement or the tractor.
4. Do not enter tractor when tractor is moving. Avoid serious injury or death from contact with rotating tires. Enter and exit the tractor only when it is completely stopped.
5. Be sure of water, gas, sewer, or electric line locations before operating implement.
6. When in transport, use accessory lights and devices for adequate warning to operators of other vehicles. Comply with all Federal, State and local laws when traveling on public roads.
7. Use “Slow Moving Vehicle” emblem for warning vehicles approaching from the rear.
8. When transporting, remember that the implement may be wider than your tractor and extreme care must be taken to allow for safe clearance.
9. Never allow inexperienced or untrained personnel to operate the implement or tractor without supervision.
10. When using compressed air to clean implement, wear safety glasses.
11. Check all fasteners for tightness or damage before and after operation. Repair immediately if required.
12. Store implement in a stable position. Insure that safety stands are extended and locked in place before detaching from tractor.



T. G. SCHMEISER CO., INC.

FOLDING TILL AN' PAK ASSEMBLY

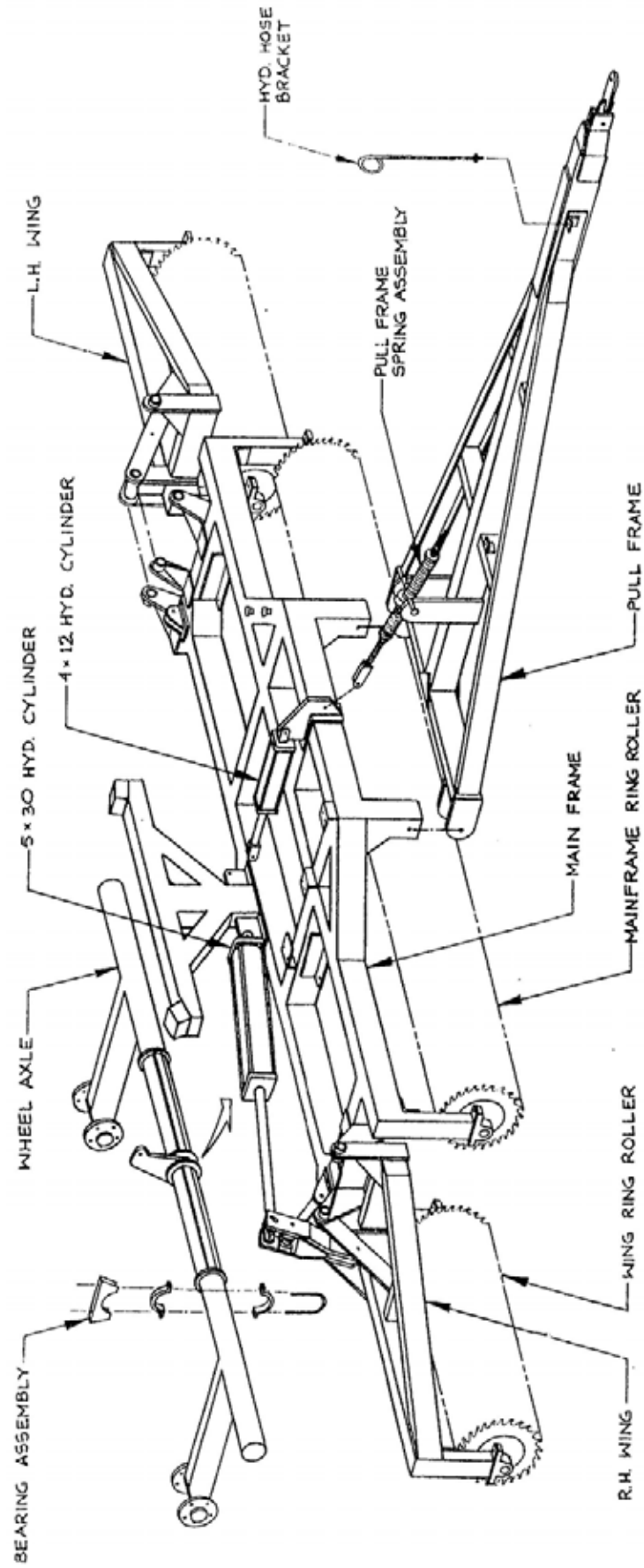



20' - 24' DOUBLE SPRING, SINGLE CYLINDER UNITS (12' SQUARE MAIN FRAME)

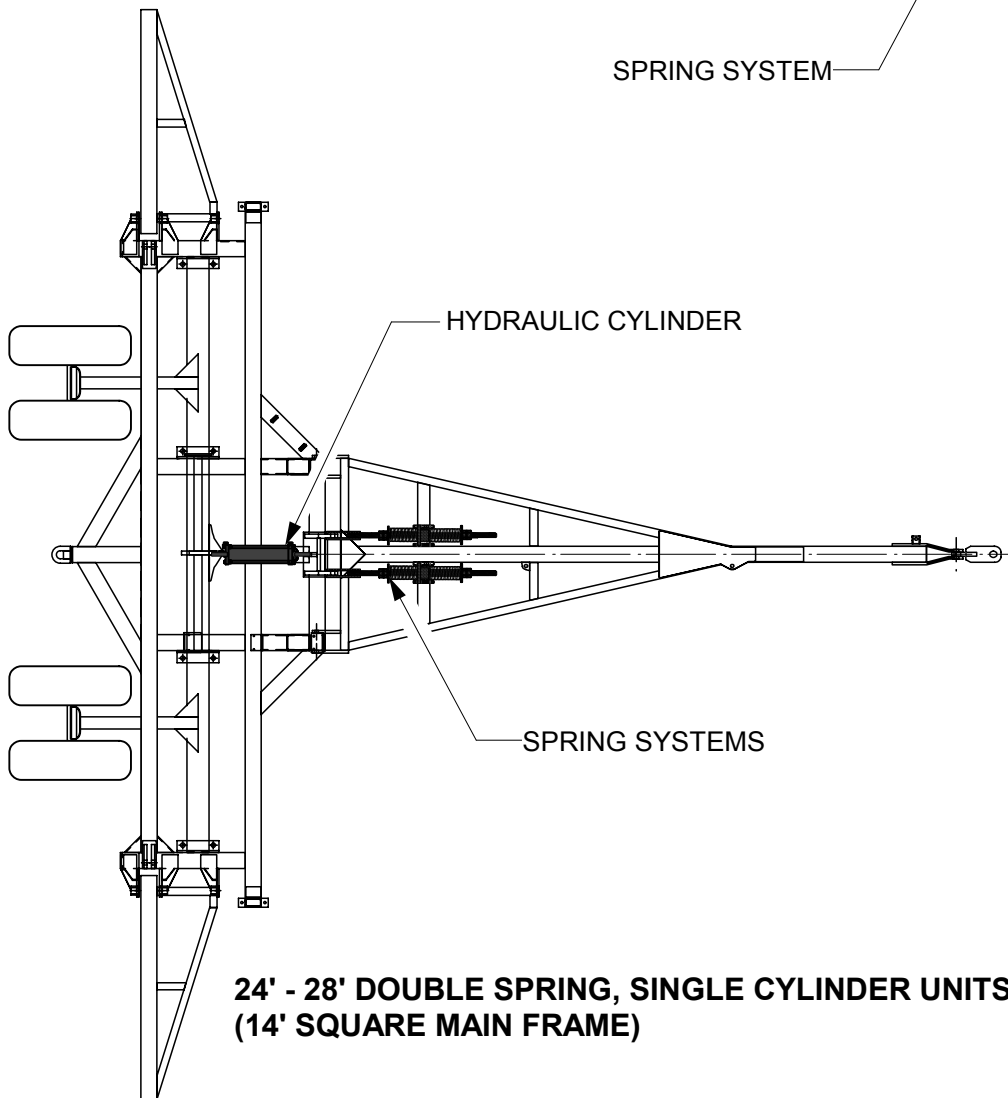
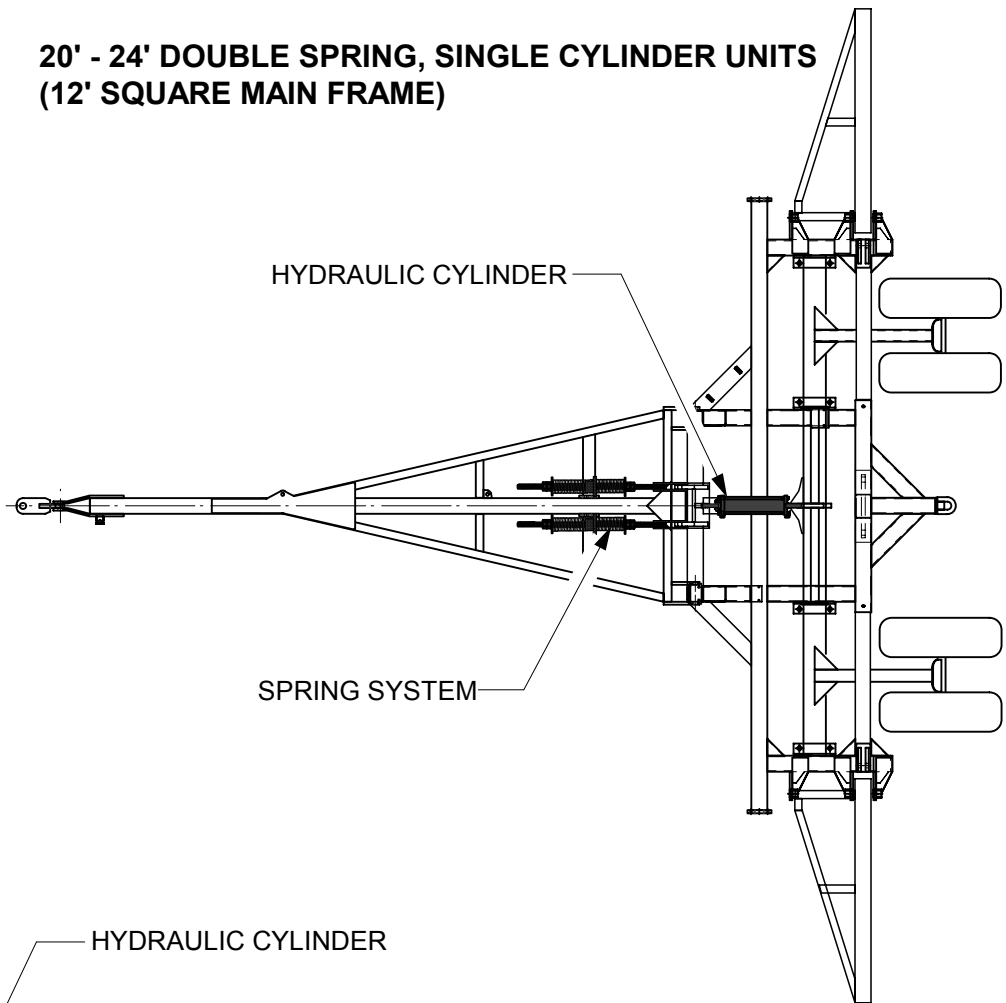

24' - 28' DOUBLE SPRING, SINGLE CYLINDER UNITS (14' SQUARE MAIN FRAME)



25' - 32' DOUBLE SPRING, SINGLE CYLINDER UNITS (12' OFFSET MAIN FRAME)

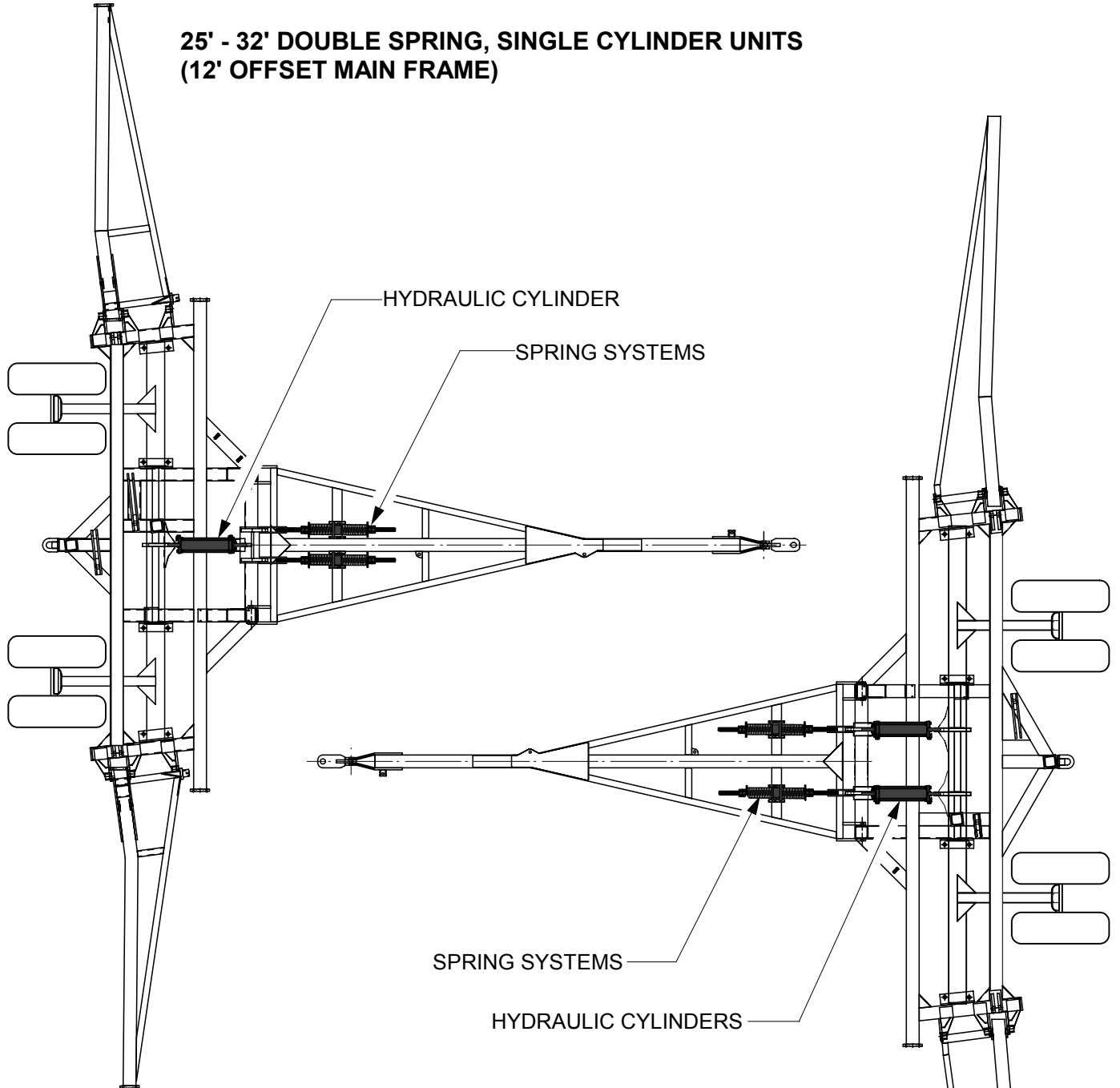

29' - 38' DOUBLE SPRING, DOUBLE CYLINDER UNITS (14' OFFSET MAIN FRAME)



FOLDING TILL AN' PAK HITCH ASSEMBLY

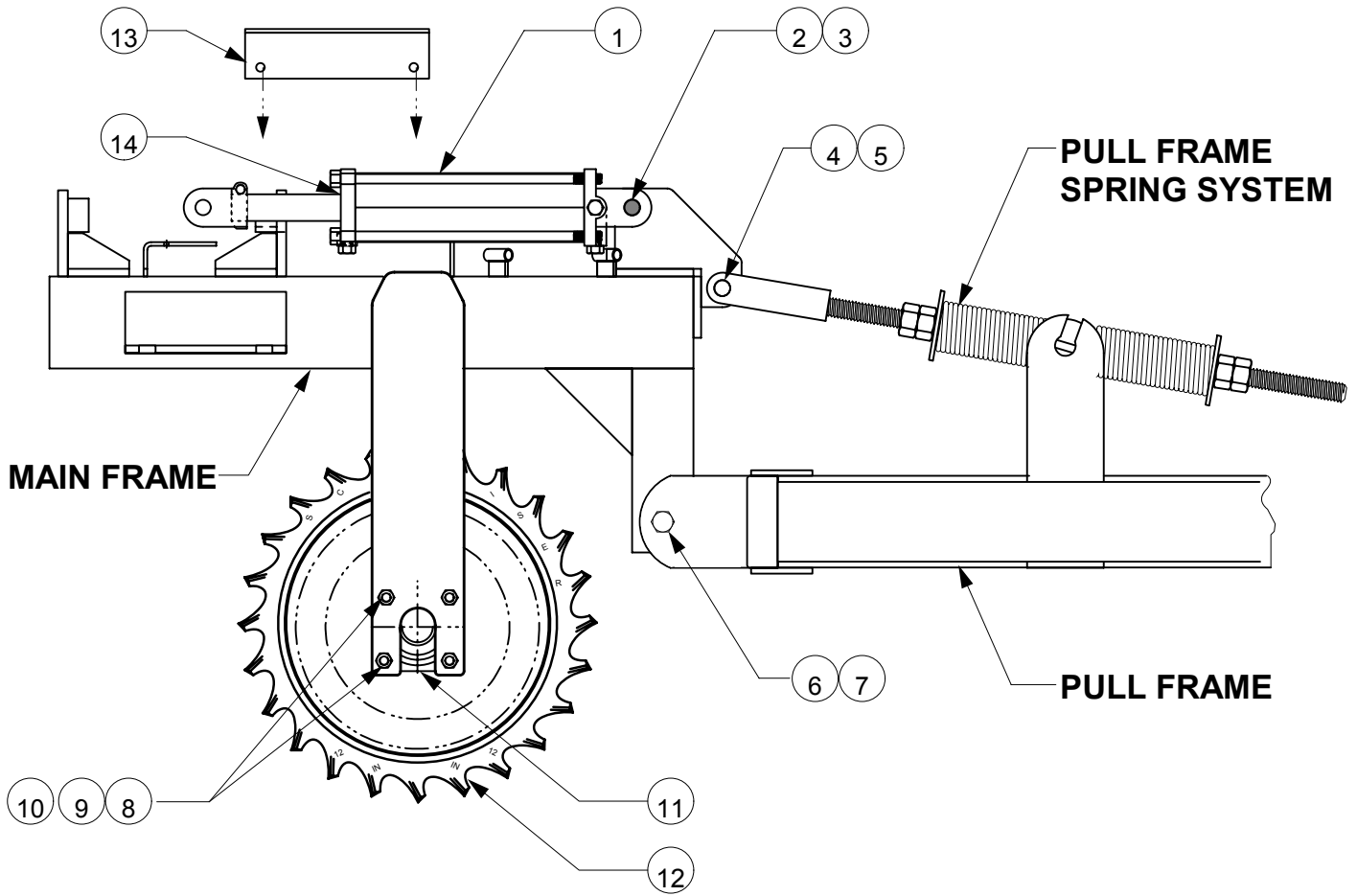

<u>Ref No.</u>	<u>New Part No.</u>	<u>Old Part No.</u>	<u>Description</u>	<u>Qty.</u>
1.	GHC-40120T		4" X 12" Tie Rod Hydraulic Cyl.	1
2.	GPN-1656HC		1" X 3-1/2" Cylinder Pin	1
3.	GPN-02CLIP		3/32" Wire Diameter Hair Pin Clip	2
4.	GPN-16X048		1" X 3" Clevis Pin	1
5.	GPN-04X40C		1/4" X 2-1/2" Cotter Pin	1
6.	CSNC814120		7/8" X 7-1/2" NC Cap Screw Gr. 8	1
7.	NYNUT-14NC		7/8" NC Nylon Hex Nut	1
8.	HXNUT-08NC		1/2" NC Hex Nut	8
9.	CSNC508036		1/2" X 2-1/4" NC Cap Screw Gr. 5	8
10.	LWASHER-08		1/2" Lock Washer	8
11.	TPP 3152	TPP 3152	1-11/16" Flange Bearing for Roillers 15' and under *	6 (for MF and Wings)
	TPP 3157	TPP 3157	1-15/16" Flange Bearing for Rollers 16' and up *	2 (for MF only)
12.	-----		Specify Ring Size	5 /ft
13.	GWD-412LB2		Lockout Bar for 4" x 12" Hydraulic Cylinder	1
14.	PMCK-34000		Seal Kit for 4" x 12" Hydraulic Cylinder	1

* NOTE: Models, fabricated before July 1997, use 1-11/16" and 1-15/16" Pillow Block Bearings.



T. G. SCHMEISER CO., INC. **FOLDING TILL AN' PAK PULL FRAME ASSEMBLY**

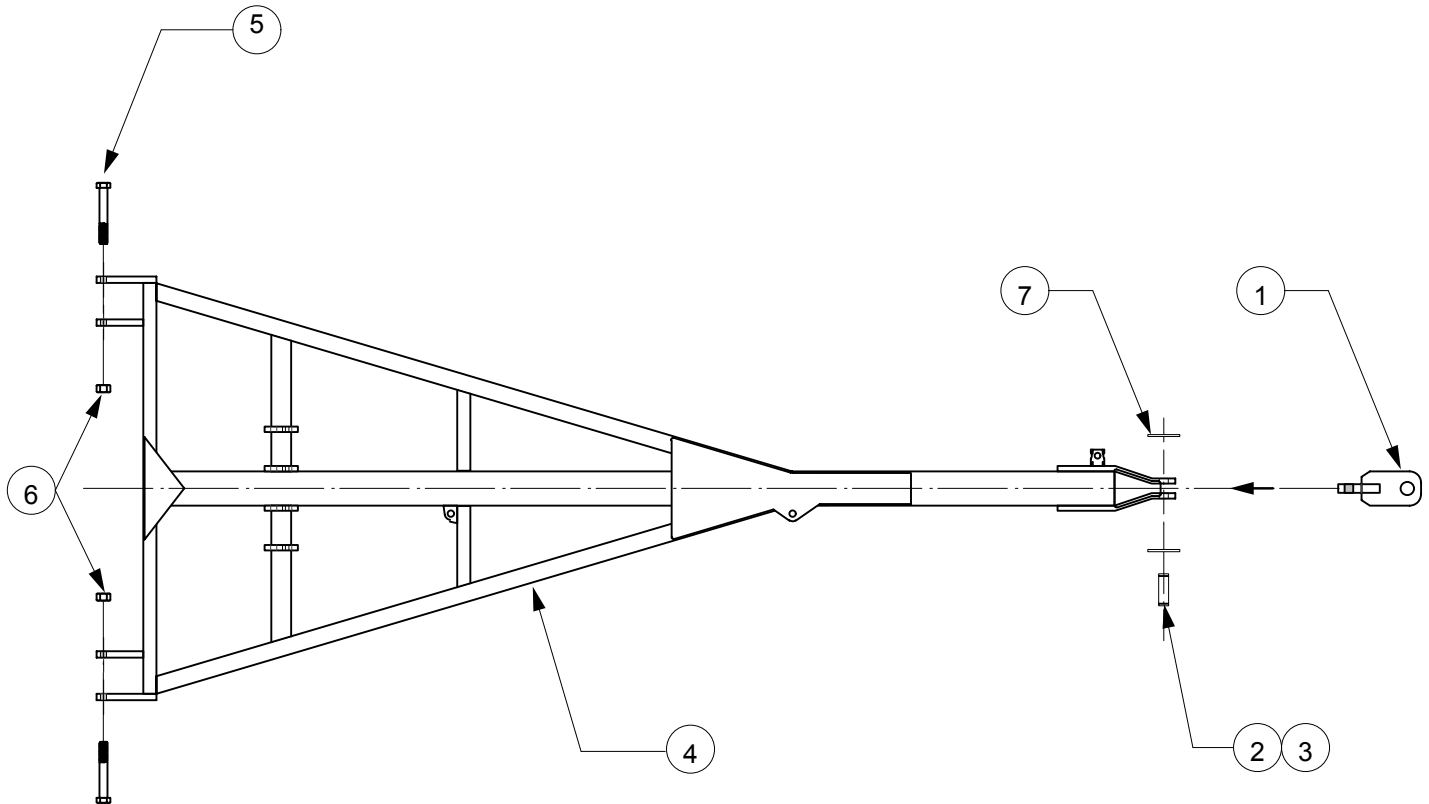

<u>Ref No.</u>	<u>Part No.</u>	<u>Description</u>	<u>Qty.</u>
1.	FTP-00C000	Folding Till An' Pak Single Lip Hitch	1
2.	GPN-2064HC	1-1/4" X 4" Cylinder Pin	1
3.	GPN-03CLIP	5/32" X 3" Overall Hair Pin Clip	2
4.	FTP-00P000	Pull Frame, Single Spring, Single Cylinder Units	1
	FTP-00P100	Pull Frame, Double Spring, Single Cylinder Units	1
	FTP-00P200	Pull Frame, Double Spring, Double Cylinder Units	1
5.	CSNC814120	7/8" X 7-1/2" NC Cap Screw Gr.8	2
6.	NYNUT-14NC	7/8" Nylon NC Hex Nut	2
7.	FWASHER-20	1-1/4" Flat Washer	2

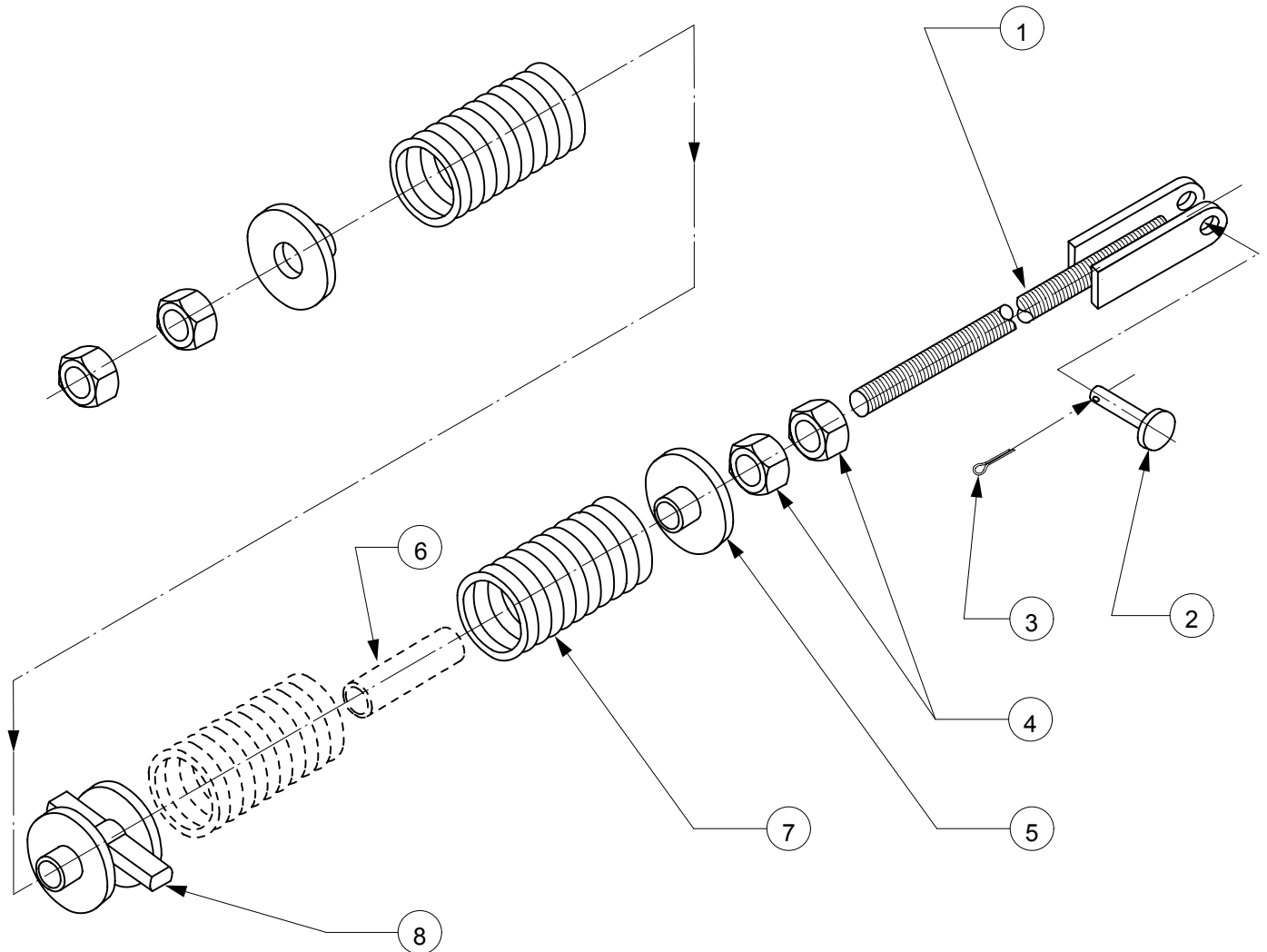

Ref No.	Part No.	Description	1 Spr. Q-ty	2 Spr. Q-ty
1.	FTP-00S000	Pull Frame Spring Rod Weldment	1	2
2.	GPN-16X048	1" Ø X 3" Clevis Pin	1	2
3.	GPN-04X40C	1/4" X 2-1/2" Cotter Pin	1	2
4.	HXNUT-20NC	1-1/4" Standard NC Hex Nuts	4	8
5.	FTP-00S100	Pull Frame Spring Washer Weldment	2	4
6*	FTP-00S004	Pull Frame Spring Bushing	-	1*
7.	GSR-BUSH01	Pull Frame Spring	2	4 or 6*
8.	FTP-00E000	Pad Eye Weldment	1	2

* NOTE: Req'd for 29' and up Folding Till An' Paks only.

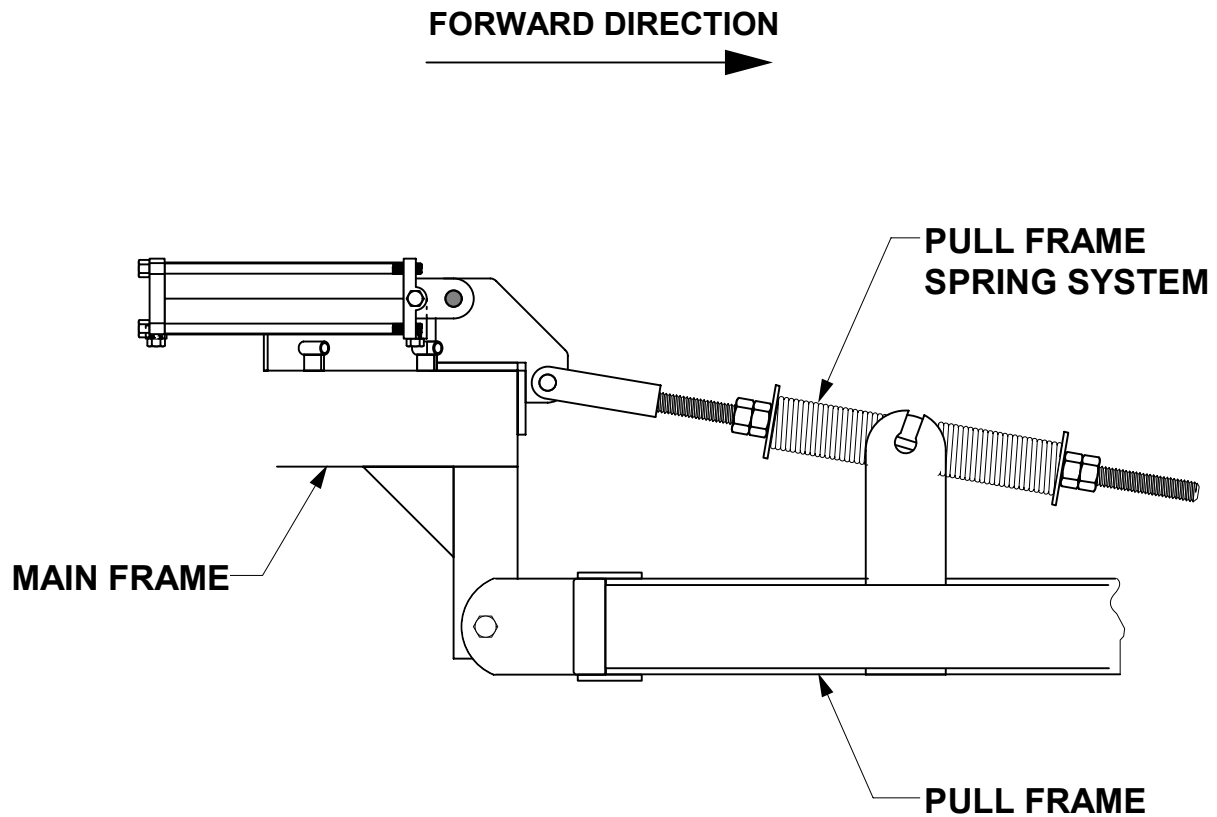

- **ADJUST ROD FORWARD TO PUT MORE PRESSURE ON FRONT ROLLER**
- **ADJUST ROD BACK TO PUT MORE PRESSURE ON WING ROLLERS**
- **INSURE THAT SPRINGS ARE TIGHT ON BOTH SIDES OF TRUNNION PAD EYE**

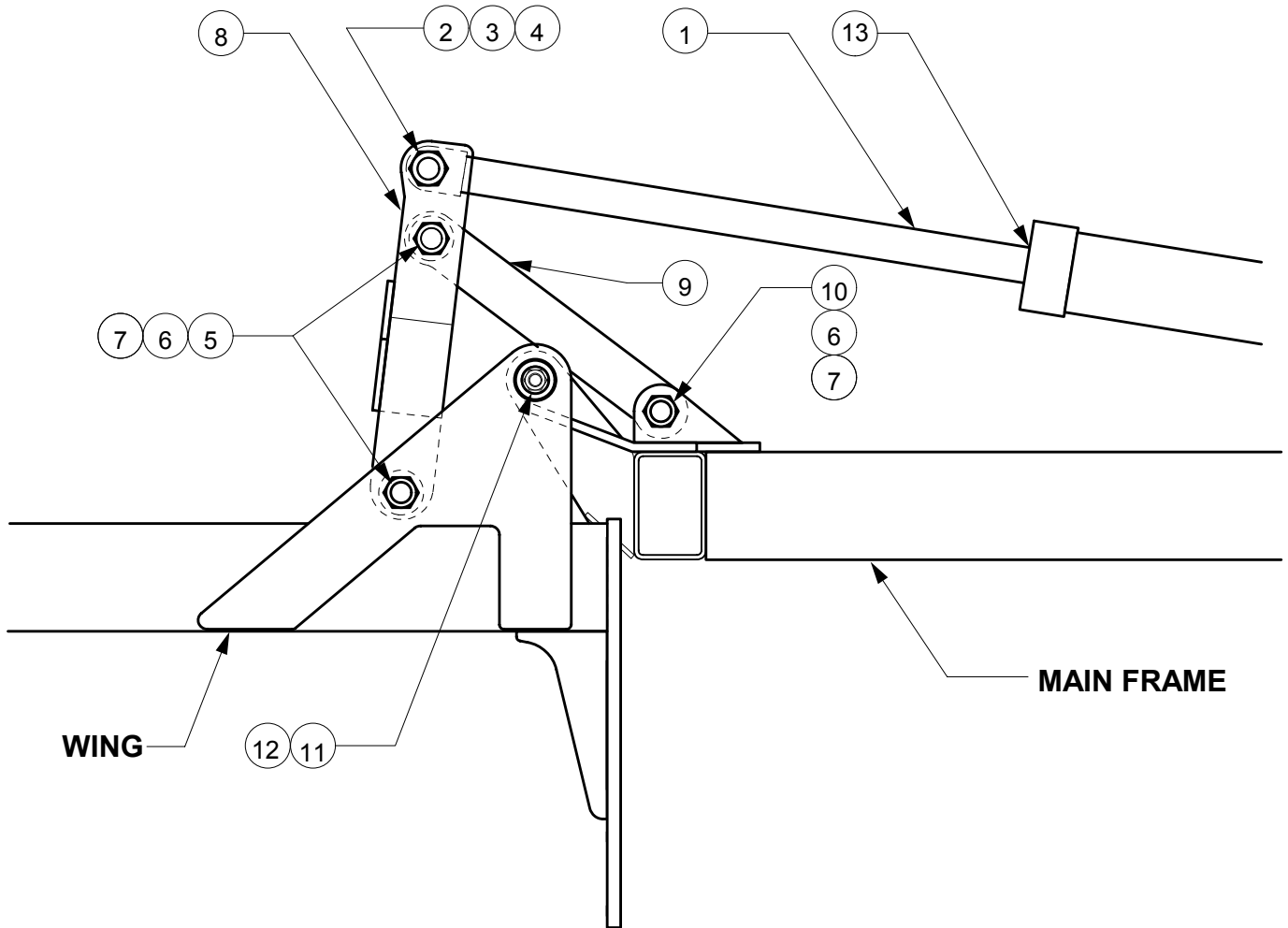

<u>Ref No.</u>	<u>Part No.</u>	<u>Description</u>	<u>Qty./Unit</u>
1.	GHC-50300T	5" x 30" Hydraulic Cylinder	2
2.	CSNC820112	1-1/4" x 7" NC Cap Screw Gr.8	2
3.	HXNUT-20NC	1-1/4" NC Hex Nut	2
4.	LWASHER-20	1-1/4" Lock Washer	2
5.	CSNC818112	1-1/8" x 7" NC Cap Screw Gr.8	4
6.	HXNUT-18NC	1-1/8" NC Hex Nut	4
7.	LWASHER-18	1-1/8" Lock Washer	4
8.	GWD-WHLINK	Hinge Link Weldment	2
9.	GPR-L10003	Loose Link	2
10.	CSNC818080	1-1/8" x 5" NC Cap Screw Gr.8	2
11.	GPN-HING01	1-1/2" x 9-1/2" Hinge Pin (Back)	2
12.	GPN-HING02	1-1/2" x 4-1/2" Hinge Pin (Front)	2
13.	PMCK-3500	Seal Kit for 5" x 30" Hydraulic Cylinder	1



WHEEL AXLE BEARING ASSEMBLY

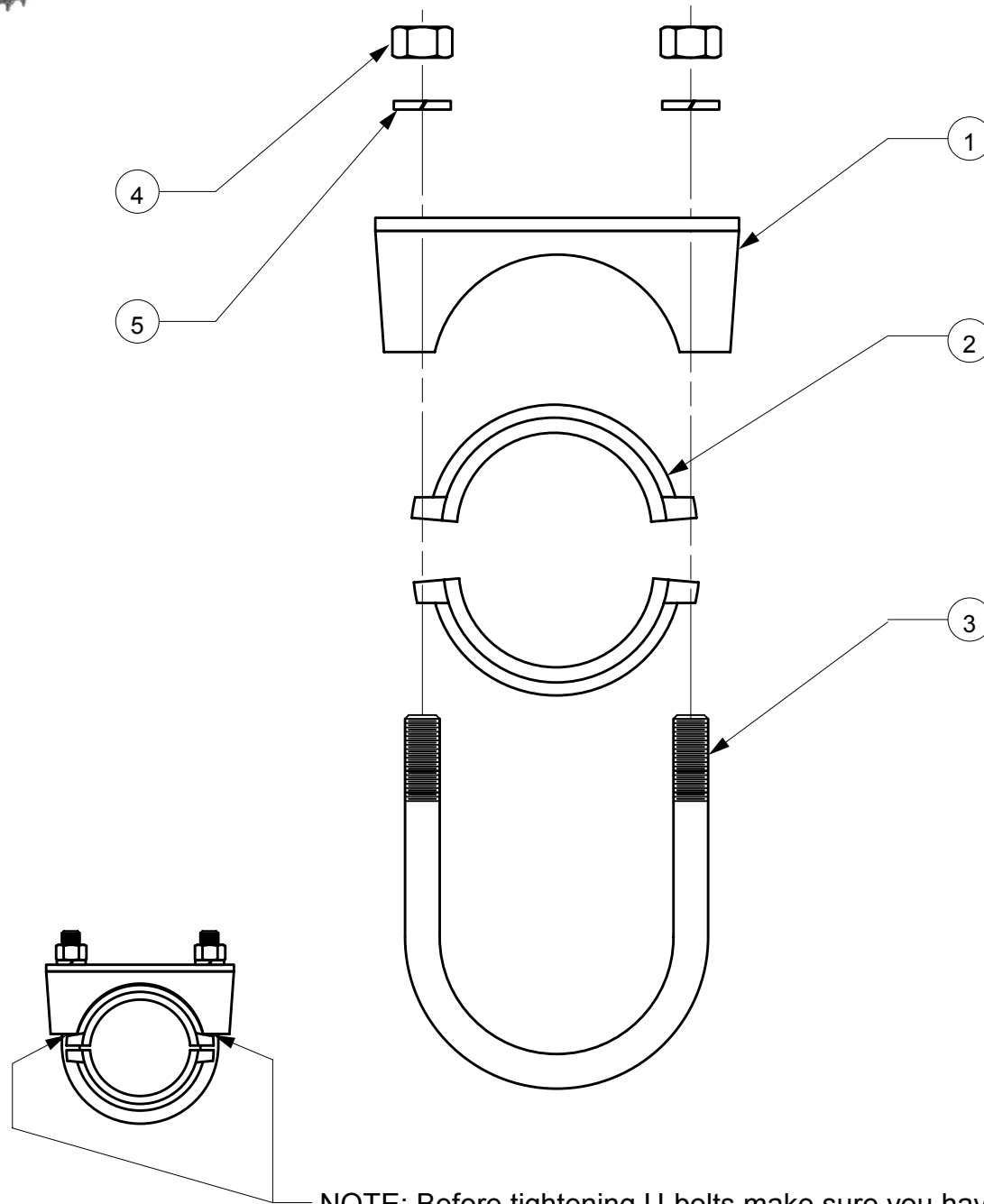

NOTE: Before tightening U-bolts make sure you have equal amount of space on each side.

<u>Ref No.</u>	<u>Part No.</u>	<u>Description</u>	<u>Qty.</u>
1.	SLL 1351	Bearing Cradle Cap Weldment	4
2.	SLL 1350	Bearing Cap Casting Machined	8
3.	UBNC16122R	1" Bearing U-bolt	4
4.	HXNUT-16NC	1" NC Hex Nut	8
5.	LWASHER-16	1" Lock Washer	8
	SLL 1352	U-Bolt Assembly (includes items 3, 4, and 5)	
	SLL 1353	Axle Bearing Assembly (includes items 1, 2, 3, 4, and 5)	



T. G. SCHMEISER CO., INC. FOLDING TILL AN' PAK WHEEL AXLE ASSEMBLY

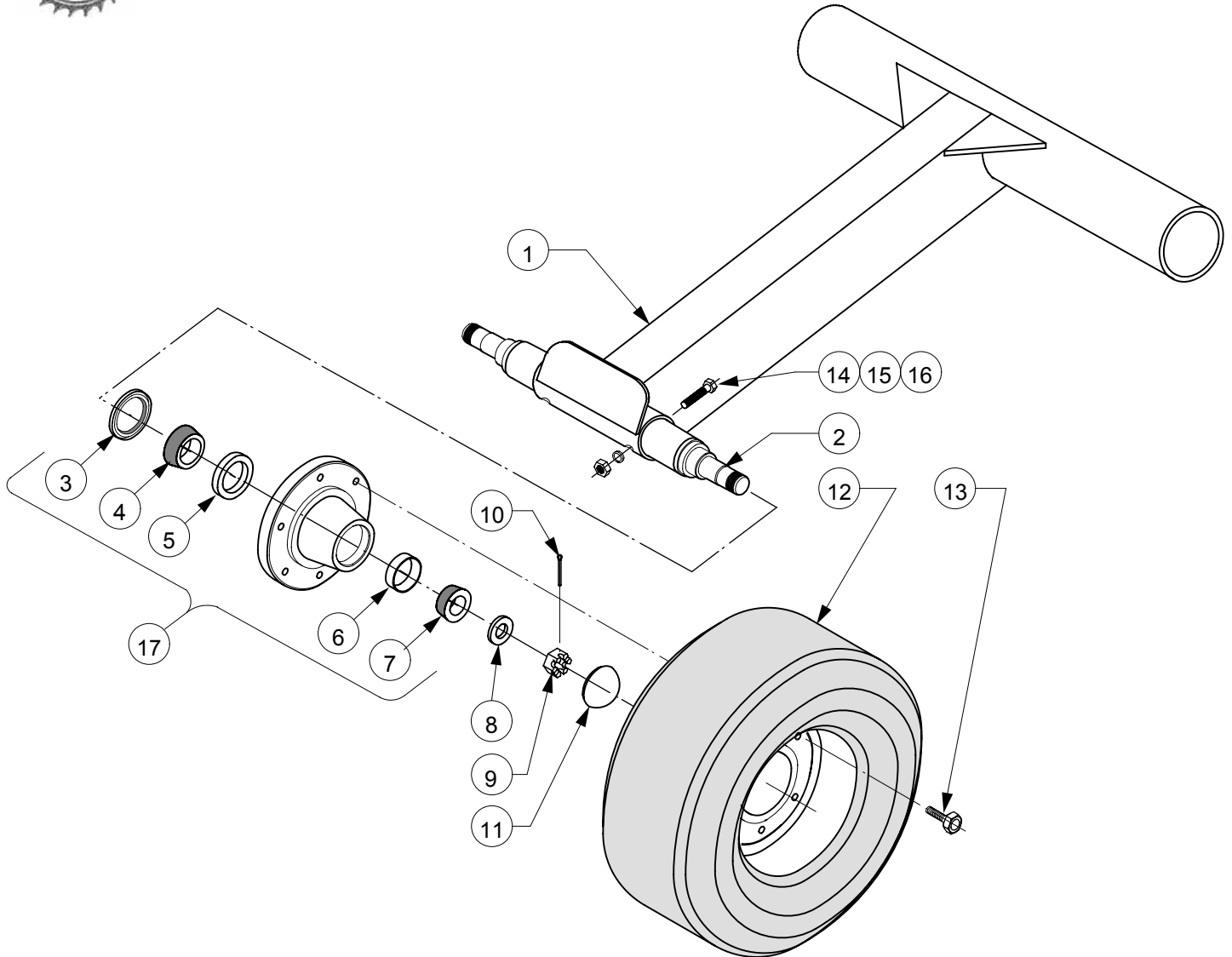

<u>Ref No.</u>	<u>Part No.</u>	<u>Description</u>	<u>Qty.</u>
1.	FTP-00A000	Wheel Axle Weldment (specify main frame size and configuration)	1
2.	TBU-01G016	2" x 20-1/4" Double Ended Removable Spindle	2
3.	GHB-6X6GSL	Grease Seal CR16289	4
4.	GHB-6X6ICN	Inner Bearing Cone	4
5.	GHB-6X6IRC	Inner Bearing Cup	4
6.	GHB-6X6ORC	Outer Bearing Cup	4
7.	GHB-6X6OCN	Outer Bearing Cone	4
8.	FWASHER-14	7/8" Flat Washer	4
9.	GSP-14CANT	Spindle Castle Nut	4
10.	GPN-03X32C	3/16" x 2" Cotter Pin	4
11.	GHB-6X6CAP	Hub Cap	4
12.	GWT-951508	9.5 x 15 8 Ply Tire with Wheel	4
13.	WHB-08X016	Wheel Bolts for 6 on 6 Standard Hub	24
14.	CSNC507056	7/16" X 3-1/2" NC Cap Screw with Lock Washer and Hex Nut	4
15.	LWASHER-07	7/16" Lock Washer	4
16.	HXNUT-07NC	7/16" NC Hex Nut	4
17.	GHB-6X6STD	Standard 6 x 6 Hub Assembly Complete	
	GSP-32324DK	2" x 20-1/4" Double Ended Spindle Kit (includes items 2, 8, 9, 10)	

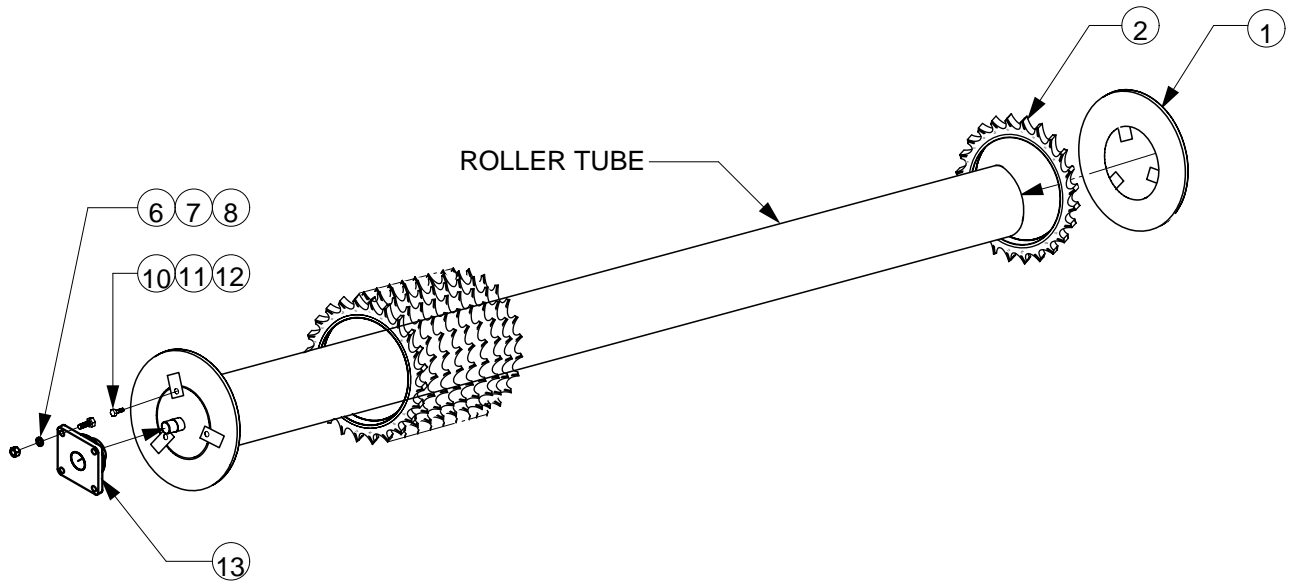

<u>Ref No.</u>	<u>Part No.</u>	<u>Description</u>	<u>Qty. per Roller</u>
1.	-----	Till An' Pak Roller Retainer (See page 16 for all sizes)	2
2.	-----	Till An' Pak Roller Ring (See page 16 for all sizes)	5 / ft.
6.	CSNC508036	1/2" X 2-1/4" NC Cap Screw (2 ft to 15 ft units)	4
	CSNC510040	5/8" X 2-1/2" NC Cap Screw (16 ft and up)	4
7.	LWASHER-08	1/2" Lock Washer (2 ft to 15 ft units)	4
	LWASHER-10	5/8" Lock Washer (16 ft and up)	4
8.	HXNUT-08NC	1/2" NC Hex Nut (2 ft to 15 ft units)	4
	HXNUT-10NC	5/8" NC Hex Nut (16 ft and up)	4
10.	CBNC510020	5/8" X 1-1/4" NC Carriage Bolt	6
11.	LWASHER-10	5/8" Lock Washer	6
12.	HXNUT-10NC	5/8" NC Hex Nut	6
13.	TPP3152	1-11/16" Flange Bearing (2 ft to 15 ft units)	2
	TPP3157	1-15/16" Flange Bearing (16 ft and up)	2



Tube Size	Ring Size (ID / OD)	Ring Part #	Retainer Size (ID - OD)	Retainer Part #
8"	10 / 14	TPP3350	8 - 12	TPP3201
8"	12 / 16	TPP3351	8 - 14	TPP3202
8"	12 / 17	TPP3357	8 - 14	TPP3202
8"	13 / 17	TPP3352	8 - 16	TPP3203
8"	14 / 20	TPP3353	8 - 18	TPP3204
8"	16 / 22	TPP3354	8 - 20	TPP3205
10"	12 / 16	TPP3351	10 - 14	TPP3206
10"	12 / 17	TPP3357	10 - 14	TPP3206
10"	13 / 17	TPP3352	10 - 16	TPP3207
10"	14 / 20	TPP3353	10 - 18	TPP3208
10"	16 / 22	TPP3354	10 - 20	TPP3209
12"	14 / 20	TPP3353	12 - 18	TPP3210
12"	16 / 22	TPP3354	12 - 20	TPP3211
14"	16 / 22	TPP3354	14 - 20	TPP3212

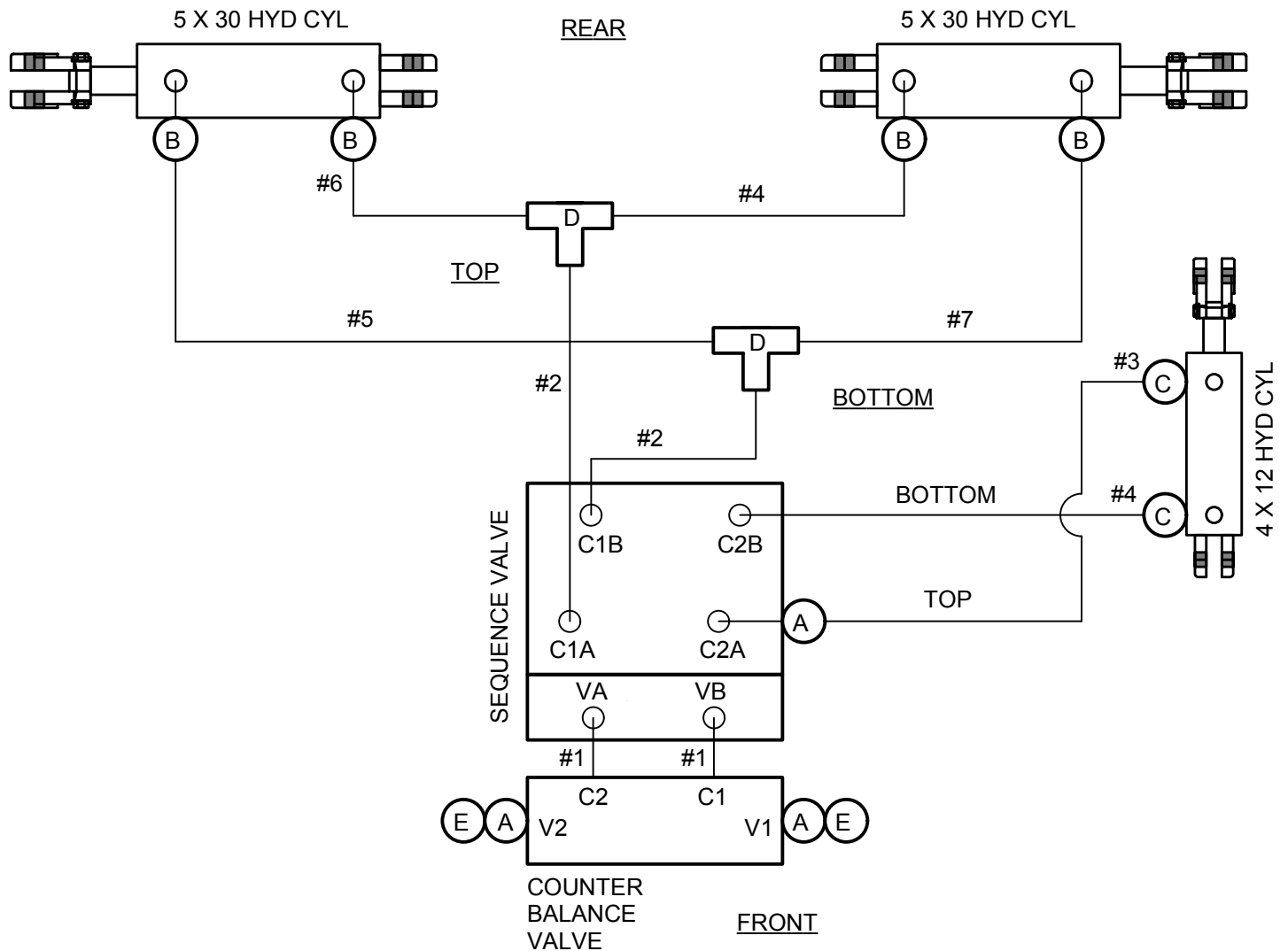

FITTINGS

- A. (3) MP-FPX 90° 8-8
- B. (4) MB-FPX 90° 10-8
- C. (2) MB-FPX 90° 8-8
- D. (2) FPT-8 TEE
- E. (2) 8MP PLUG

HOSES

- #1 - (2) 1/2" MP-1/2" MPX 13 1/2" LONG
- #2 - (2) 1/2" MP-1/2" MPX 19" LONG
- #3 - (1) 1/2" MP-1/2" MP 21" LONG
- #4 - (2) 1/2" MP-1/2" MP 36" LONG
- #5 - (1) 1/2" MP-1/2" MP 25" LONG
- #6 - (1) 1/2" MP-1/2" MP 38" LONG
- #7 - (1) 1/2" MP-1/2" MP 70" LONG

HYDRAULIC CYLINDERS

- (1) GHC-40120T 4 X 12 TIE ROD CYL.
- (2) GHC-50300T 5 X 30 TIE ROD CYL.

VALVES

- (1) OVER CENTER COUNTER BALANCE VALVE:
 - (1) V08CBBSUN YAC BODY "SUN"
 - (2) V08CBCARTR CBEA LAN CARTRIDGE
- (1) V08SEQVSUN SEQUENCE VALVE

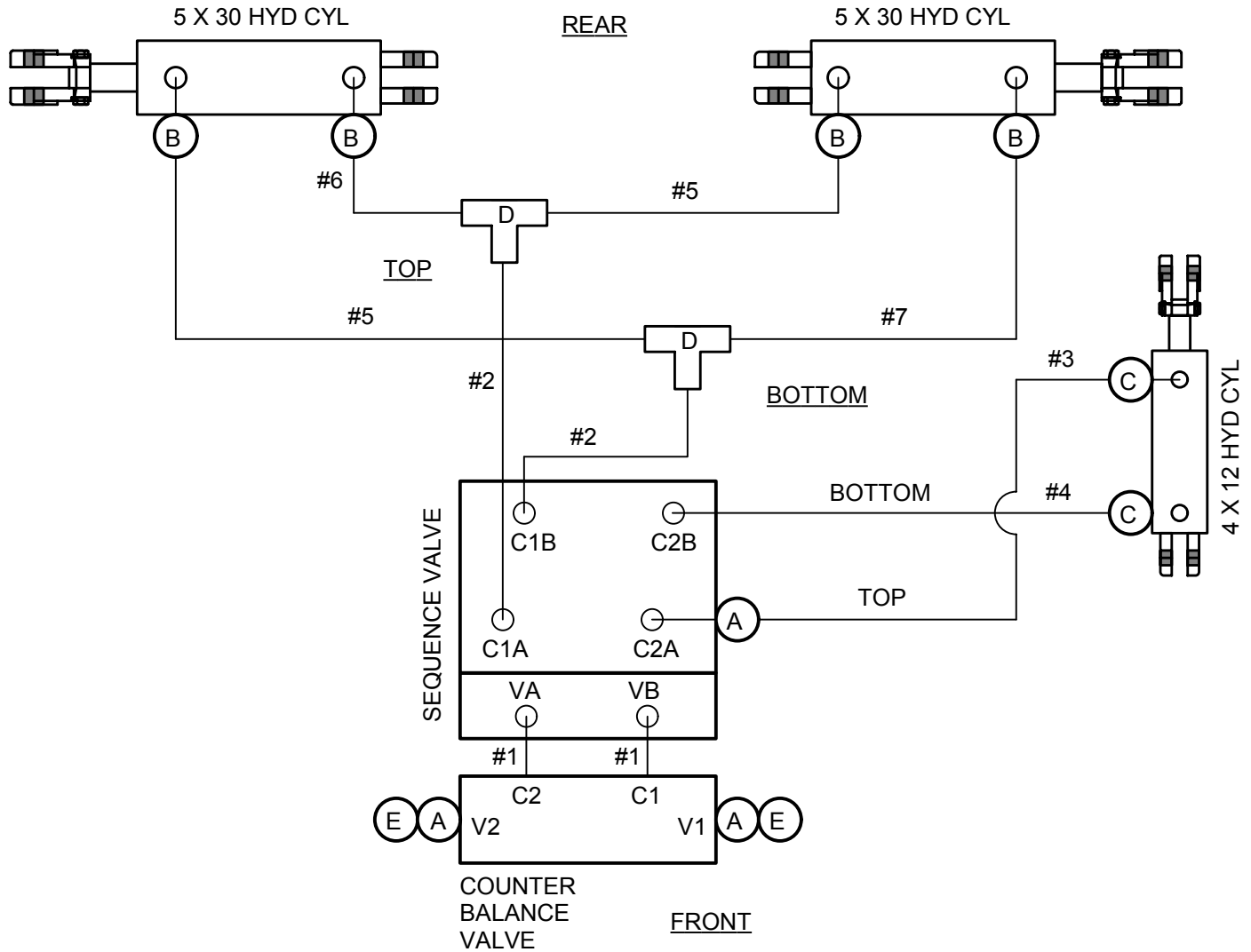

FITTINGS

- A. (3) MP-FPX 90° 8-8
- B. (4) MB-FPX 90° 10-8
- C. (2) MB-FPX 90° 8-8
- D. (2) FPT-8 TEE
- E. (2) 8MP PLUG

HOSES

- #1 - (2) 1/2" MP-1/2" MPX 13 1/2" LONG
- #2 - (2) 1/2" MP-1/2" MP 19" LONG
- #3 - (1) 1/2" MP-1/2" MP 29" LONG
- #4 - (1) 1/2" MP-1/2" MP 34" LONG
- #5 - (2) 1/2" MP-1/2" MP 30" LONG
- #6 - (1) 1/2" MP-1/2" MP 36" LONG
- #7 - (1) 1/2" MP-1/2" MP 67" LONG

HYDRAULIC CYLINDERS

- (1) GHC-40120T 4 X 12 TIE ROD CYL.
- (2) GHC-50300T 5 X 30 TIE ROD CYL.

VALVES

- (1) OVER CENTER COUNTER BALANCE VALVE:
 - (1) V08CBBSUN YAC BODY "SUN"
 - (2) V08CBCARTR CBEA LAN CARTRIDGE
- (1) V08SEQVSUN SEQUENCE VALVE

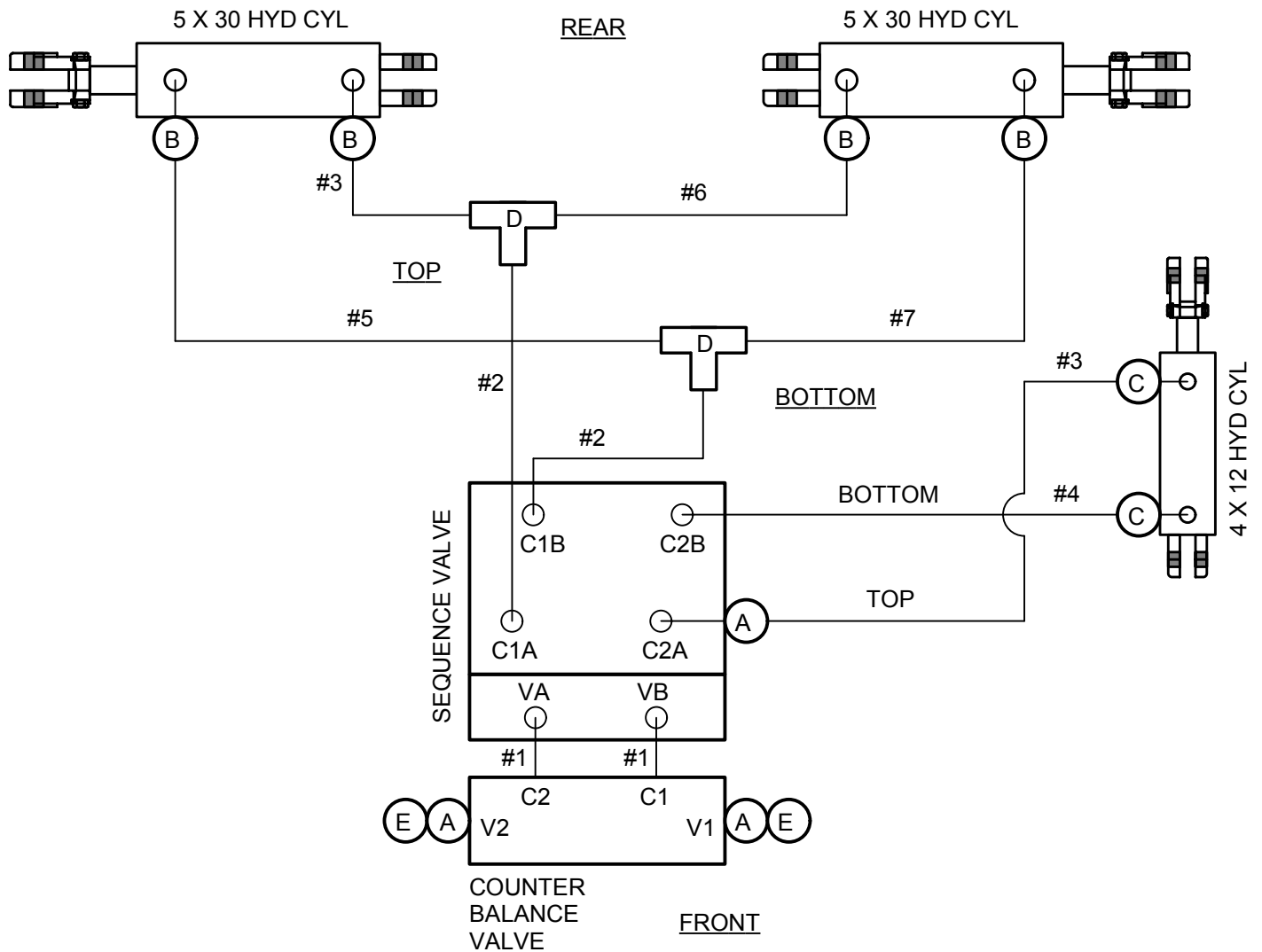

<p><u>FITTINGS</u></p> <p>A. (3) MP-FPX 90° 8-8 B. (4) MB-FPX 90° 10-8 C. (2) MB-FPX 90° 8-8 D. (2) FPT-8 TEE E. (2) 8MP PLUG</p> <p><u>HOSES</u></p> <p>#1 - (2) 1/2" MP-1/2" MPX 13 1/2" LONG #2 - (2) 1/2" MP-1/2" MPX 19" LONG #3 - (2) 1/2" MP-1/2" MP 27" LONG #4 - (1) 1/2" MP-1/2" MP 36" LONG #5 - (1) 1/2" MP-1/2" MP 37" LONG #6 - (1) 1/2" MP-1/2" MP 48" LONG #7 - (1) 1/2" MP-1/2" MP 82" LONG</p>	<p><u>HYDRAULIC CYLINDERS</u></p> <p>(1) GHC-40120T 4 X 12 TIE ROD CYL. (2) GHC-50300T 5 X 30 TIE ROD CYL.</p> <p><u>VALVES</u></p> <p>(1) OVER CENTER COUNTER BALANCE VALVE (1) V08CBBSUN YAC BODY "SUN" (2) V08CBCARATR CBEA LAN CARTRIDGE</p> <p>(1) V08SEQVSUN SEQUENCE VALVE</p>
--	---

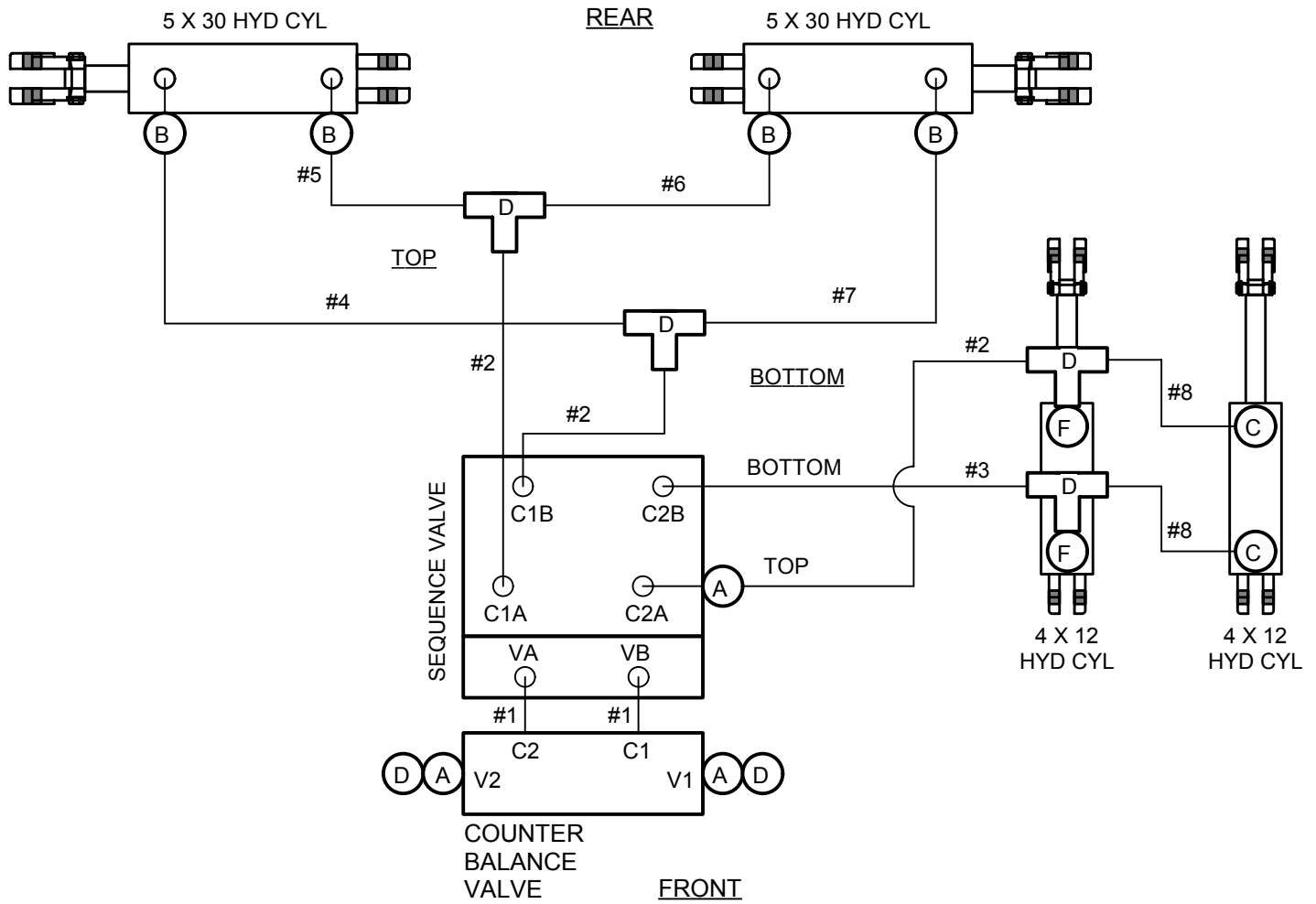

FITTINGS

- A. (3) MP-FPX 90° 8-8
- B. (4) MB-FPX 90° 10-8
- C. (2) MB-FPX 90° 8-8
- D. (4) FPT-8 TEE
- E. (2) 8MP PLUG
- F. (2) MB-MP 8-8 NIPPLE

HOSES

- #1 - (2) 1/2" MP-1/2" MPX 13 1/2" LONG
- #2 - (3) 1/2" MP-1/2" MPX 19" LONG
- #3 - (1) 1/2" MP-1/2" MPX 30" LONG
- #4 - (1) 1/2" MP-1/2" MP 38" LONG
- #5 - (1) 1/2" MP-1/2" MP 34" LONG
- #6 - (1) 1/2" MP-1/2" MP 57" LONG
- #7 - (1) 1/2" MP-1/2" MP 88" LONG
- #8 - (2) 1/2" MP-1/2" MP 28" LONG

HYDRAULIC CYLINDERS

- (2) GHC-40120T 4 X 12 TIE ROD CYL.
- (2) GHC-50300T 5 X 30 TIE ROD CYL.

VALVES

- (1) OVER CENTER COUNTER BALANCE VALVE:
 - (1) V08CBBSUN YAC BODY "SUN"
 - (2) V08CBCARTR CBEA LAN CARTRIDGE
- (1) V08SEQSUN SEQUENCE VALVE

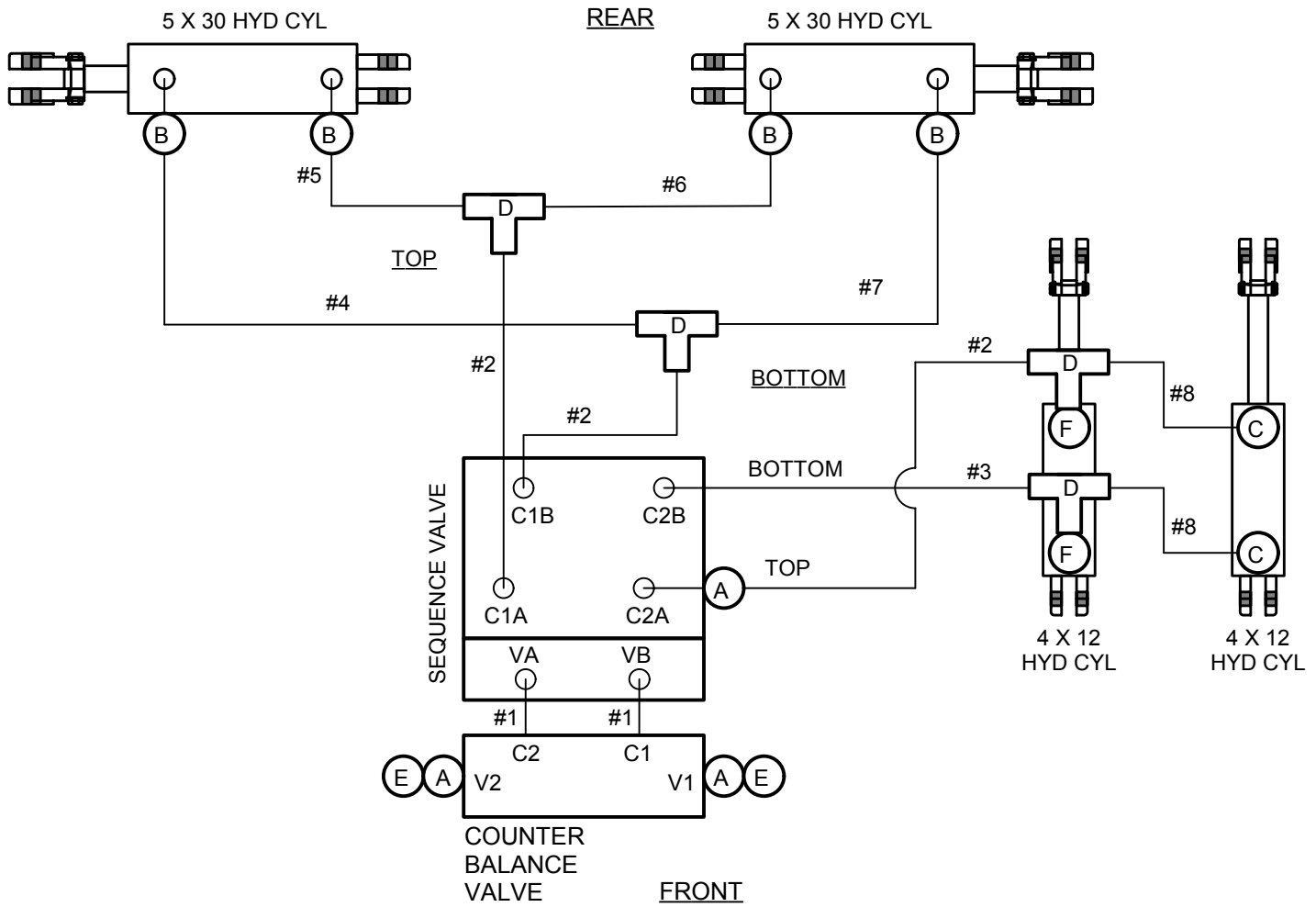

FITTINGS

- A. (3) MP-FPX 90° 8-8
- B. (4) MB-FPX 90° 10-8
- C. (2) MB-FPX 90° 8-8
- D. (4) FPT-8 TEE
- E. (2) 8MP PLUG
- F. (2) MB-MP 8-8 NIPPLE

HOSES

- #1 - (2) 1/2" MP-1/2" MPX 13 1/2" LONG
- #2 - (3) 1/2" MP-1/2" MPX 19" LONG
- #3 - (1) 1/2" MP-1/2" MPX 30" LONG
- #4 - (1) 1/2" MP-1/2" MP 37" LONG
- #5 - (1) 1/2" MP-1/2" MP 27" LONG
- #6 - (1) 1/2" MP-1/2" MP 48" LONG
- #7 - (1) 1/2" MP-1/2" MP 82" LONG
- #8 - (2) 1/2" MP-1/2" MP 28" LONG

HYDRAULIC CYLINDERS

- (2) GHC-40120T 4 X 12 TIE ROD CYL.
- (2) GHC-50300T 5 X 30 TIE ROD CYL.

VALVES

- (1) OVER CENTER COUNTER BALANCE VALVE:
 - (1) V08CBBSUN YAC BODY "SUN"
 - (2) V08CBCARTR CBEA LAN CARTRIDGE
- (1) V08SEQSUN SEQUENCE VALVE

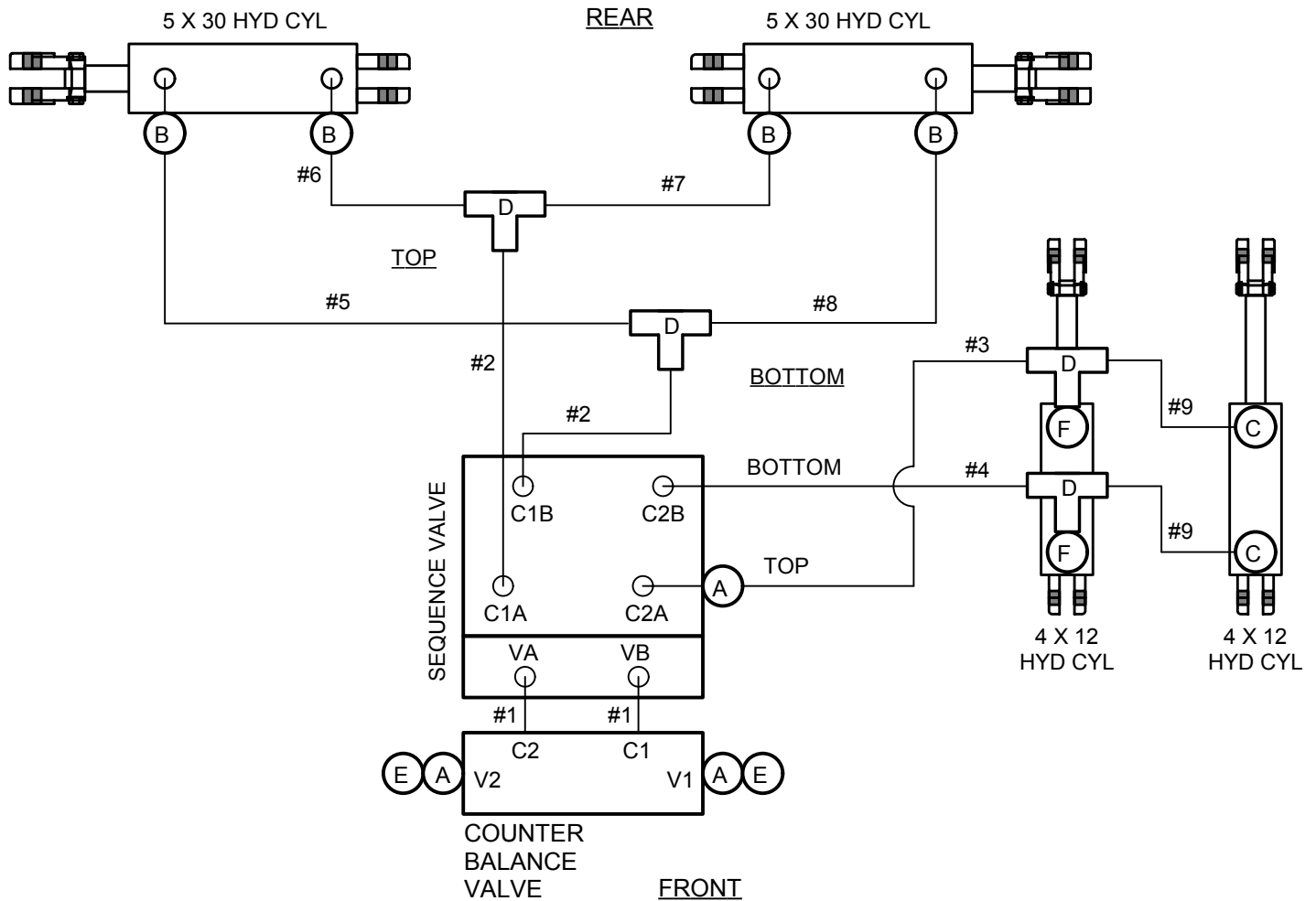

FITTINGS

- A. (3) MP-FPX 90° 8-8
- B. (4) MB-FPX 90° 10-8
- C. (2) MB-FPX 90° 8-8
- D. (4) FPT-8 TEE
- E. (2) 8MP PLUG
- F. (2) MB-MP 8-8 NIPPLE

HOSES

- #1 - (2) 1/2" MP-1/2" MPX 13 1/2" LONG
- #2 - (2) 1/2" MP-1/2" MPX 19" LONG
- #3 - (1) 1/2" MP-1/2" MPX 27" LONG
- #4 - (1) 1/2" MP-1/2" MPX 36" LONG
- #5 - (1) 1/2" MP-1/2" MP 49" LONG
- #6 - (1) 1/2" MP-1/2" MP 39" LONG
- #7 - (1) 1/2" MP-1/2" MP 60" LONG
- #8 - (1) 1/2" MP-1/2" MP 94" LONG
- #9 - (2) 1/2" MP-1/2" MP 28" LONG

HYDRAULIC CYLINDERS

- (2) GHC-40120T 4 X 12 TIE ROD CYL.
- (2) GHC-50300T 5 X 30 TIE ROD CYL.

VALVES

- (1) OVER CENTER COUNTER BALANCE VALVE:
 - (1) V08CBBSUN YAC BODY "SUN"
 - (2) V08CBCARTR CBEA LAN CARTRIDGE
- (1) V08SEQSUN SEQUENCE VALVE



PURPOSE:

To allow one hydraulic valve to operate both transport wheels and wing folding mechanism on Folding Till An' Pak.

ORDER OF OPERATION AND SEQUENCE VALVE CALIBRATION:

When converting from transport to field position, wings unfold first, then the machine lowers to ground (wheels raise up last).

If machine begins to lower before the wings completely unfold, turn the transport adjustment knob clockwise, in 1/2 turn increments, until unit performs as intended (see drawing below).

When converting from field to transport position, machine raises up first, then wings fold into transport position.

If wings begin to fold before the machine is completely raised, turn the wing adjustment knob clockwise, in 1/2 turn increments, until unit performs as intended (see drawing below).

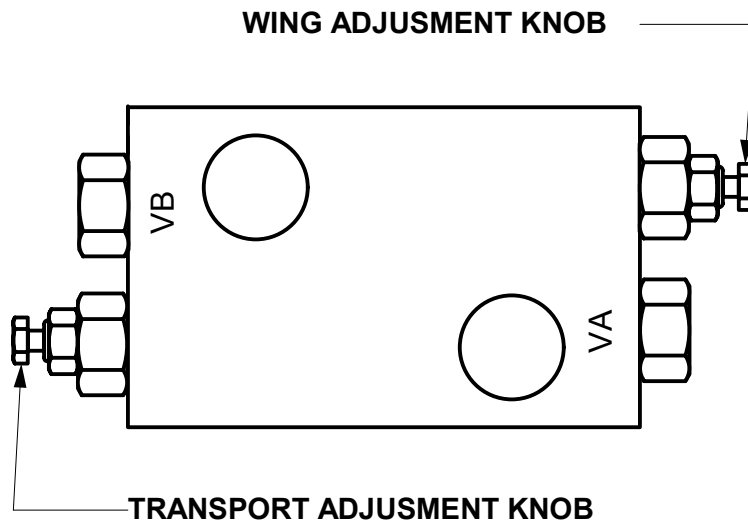

FRONT VIEW

NOTE:

Please note, the two wings will not fold or unfold at the same time.

T.G. SCHMEISER CO., INC.®

Limited Warranty Statement

T. G. Schmeiser Co., Inc. warrants each new Schmeiser® product to be free from defects in material and workmanship. This warranty is applicable only for the normal service life expectancy of the product or components, not to exceed twelve (12) consecutive months from the date of delivery of the new Schmeiser product to the original purchaser.

Genuine T. G. Schmeiser Co., Inc. replacement parts and components will be warranted for 90 days from date of purchase, or the remainder of the original equipment warranty period, whichever is longer.

Under no circumstances will it cover any merchandise or components thereof, which, in the opinion of the company, has been subjected to misuse, unauthorized modifications, alteration, an accident or if repairs have been made with parts other than those obtainable through T. G. Schmeiser Co., Inc.

The Company in no way warrants engines, batteries, cylinders, tires or other trade accessories since these items are warranted separately by their respective manufacturer. Expendable components such as points, shanks, blades, rings, bearings, teeth, and the like are excluded from this warranty.

Our obligation under this warranty shall be limited to repairing or replacing, free of charge to the original purchaser, any part that, in our judgment, shall show evidence of such defect, provided further that such part shall be returned within thirty (30) days from date of failure to T. G. Schmeiser Co., Inc., routed through the dealer and distributor from whom the purchase was made, transportation charges prepaid.

This warranty shall not be interpreted to render T. G. Schmeiser Co., Inc. liable for injury or damages of any kind or nature to person or property. This warranty does not extend to the loss of crops, loss because of delay in harvesting, or any expense or loss incurred for labor, substitute machinery, rental or for any other reason.

Except as set forth above, **T. G. Schmeiser Co., Inc. shall have no obligation or liability of any kind on account of any of its equipment and shall not be liable for special or consequential damages. T. G. Schmeiser Co., Inc. makes no other warranty, expressed or implied, and, specifically, T. G. Schmeiser Co., Inc. disclaims any implied warranty or merchantability or fitness for a particular purpose. Some states or provinces do not permit limitations or exclusions of implied warranties or incidental or consequential damages, so the limitations or exclusion in this warranty may not apply.**

This warranty is subject to any existing conditions of supply, which may directly affect our ability to obtain materials or manufacture replacement parts.

T. G. Schmeiser Co., Inc. reserves the right to make improvements in design or changes in specifications at any time, without incurring any obligation to owners of units previously sold.

No one is authorized to alter, modify or enlarge this warranty nor the exclusion, limitations and reservations.

**WARRANTY VOID IF NOT REGISTERED
WITHIN 30 DAYS OF PURCHASE DATE**